

# INSTALLATION INSTRUCTIONS FOR GLSRIM9800 NARROW HEAD RIM PANIC EXIT DEVICE FOR GLASS DOORS

**BEFORE INSTALLING DEVICE, PLEASE CHECK:**

1. IF DOOR IS MOUNTED AND HINGED SECURELY
2. SIZE OF EXIT DEVICE. FUNCTION AND DESIGN...
  - 2.1. 36"(914.4mm) DOORS, CAN BE CUT TO FIT DOORS DOWN TO 30"(762mm) WIDE.
  - 2.2. 40"(1219.2mm) DOORS, CAN BE CUT TO FIT DOORS DOWN TO 36"(914.4mm) WIDE.
  - 2.3. HAND OF DEVICE AGAINST APPLICATION.

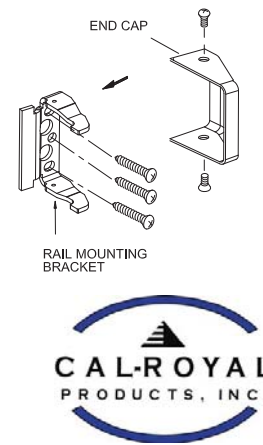
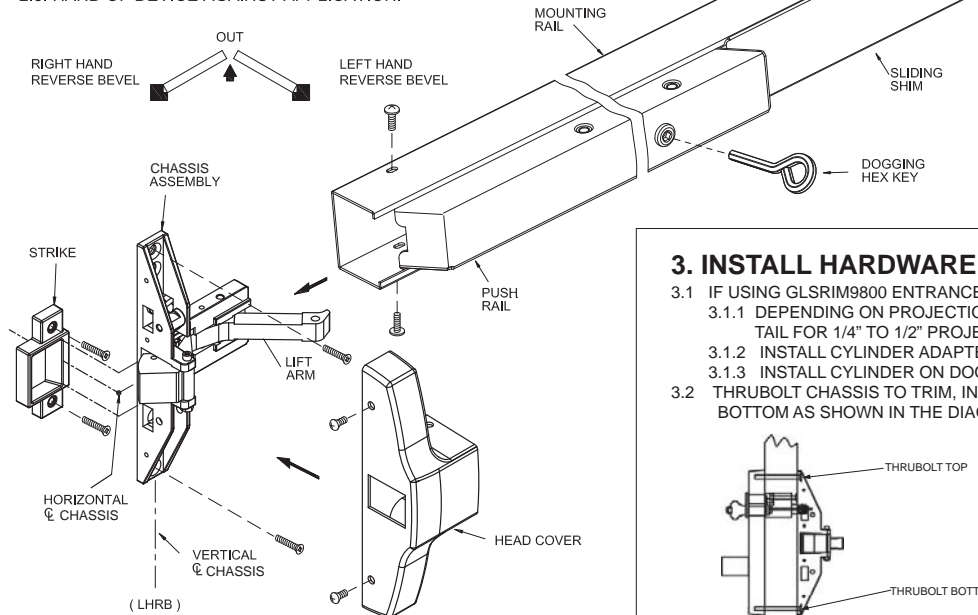

## 1. LOCATE AND MARK THE HORIZONTAL AND VERTICAL CENTER LINES ON THE DOOR

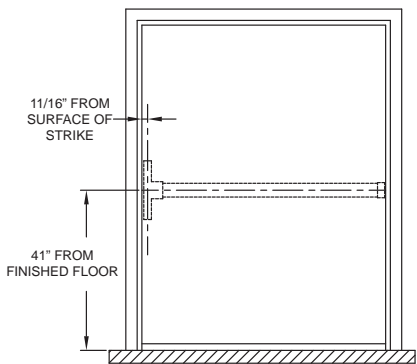

## 2. PREPARING THE DOOR

- 2.1 USING STRIPS OF TAPE, AFFIX THE TEMPLATES ON INSIDE OF THE DOOR, ALIGNING THE MARKED REFERENCE LINES ON THE DOOR AND THE HORIZONTAL AND VERTICAL CENTERLINES OF THE TEMPLATE.
- 2.2 IF USING OUTSIDE TRIMS, MARK ALL REFERENCE LINES ON THE OTHER SIDE OF DOOR USING THE TRIM TEMPLATES
- 2.2 MAKE PILOT HOLE MARKS ON ALL DRILL HOLES
- 2.3 DRILL ALL REQUIRED HOLES

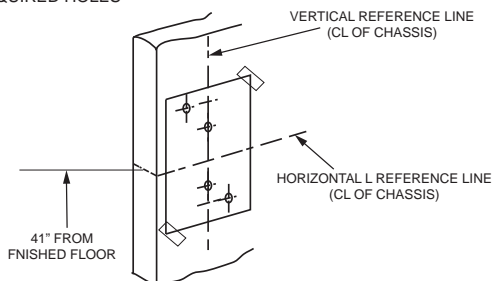

## 3. INSTALL HARDWARE

- 3.1 IF USING GLSRIM9800 ENTRANCE LEVER TRIM:
  - 3.1.1 DEPENDING ON PROJECTION THRU DOOR, CUT CYLINDER TAIL FOR 1/4" TO 1/2" PROJECTION
  - 3.1.2 INSTALL CYLINDER ADAPTER ON RIM CYLINDER
  - 3.1.3 INSTALL CYLINDER ON DOOR
- 3.2 THRUBOLT CHASSIS TO TRIM, INSIDE DOOR SURFACE, TOP AND BOTTOM AS SHOWN IN THE DIAGRAM BELOW:

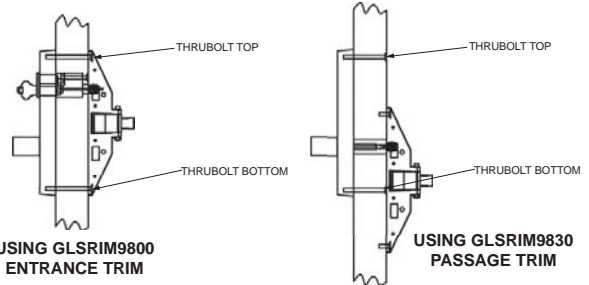

TRIM CYLINDER TAIL FOR 1/4" TO 1/2" PROJECTION THRU DOOR

IMPORTANT: CYLINDER ADAPTER MUST BE INSTALLED ON CYLINDER BEFORE INSTALLING CYLINDER INTO DOOR

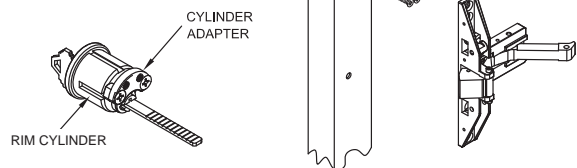

## 4. FASTEN RAIL ASSEMBLY

- 4.1 IF EXIT DEVICE REQUIRES CUTTING TO SIZE:
  - 4.1.1 DETERMINE CUT OFF LENGTH "X" BY SUBTRACTING 1-3/4" FROM "Y"
  - 4.1.2 MARK CUT OFF POINT IN MOUNTING RAIL
  - 4.1.3 CUT OFF AN DEBURR
- 4.2 PRESS DOWN ARM INTO RAIL OPENING AND PUSH IN RAIL ONTO THE CHASSIS.
- 4.3 LEVEL RAIL AND FASTEN MOUNTING PLATE

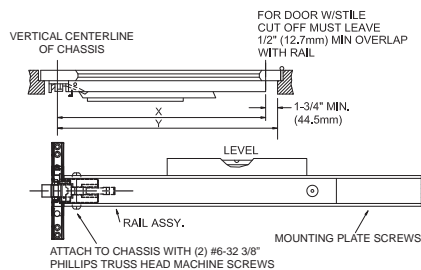

CUT OFF AND DEBURR

DO NOT CUT CLOSER THAN 1-3/4" (44.5mm) FROM LOWER PIVOT



SNUG AGAINST MOUNTING RAIL

ATTACH MOUNTING PLATE TO DOOR WITH (3) ROUND HEAD SCREWS.